

DESCRIPTION

The MCV116 Pressure Control Pilot (PCP) Valve is an inexpensive control valve for use in electrohydraulic systems which control machines used in construction, farming, material handling, marine, mining and industrial applications. The device is designed to control pilot-operated flow control valves (proportional main spool valves in the 5–50 gpm range), pilot-operated variable displacement pumps and motors and any other device which is pilot differential pressure actuated.

The PCP is a torque-motor actuated, double-nozzle flapper valve that produces a differential output pressure proportional to the applied electrical input signal. It is a single-stage, stand-alone, closed loop pressure control valve which uses internal hydraulic pressure reactions to achieve its closed loop control characteristics.

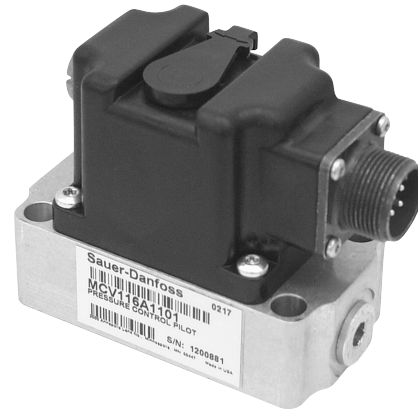

THEORY OF OPERATION

The PCP accepts a dc current and produces a proportional hydraulic differential pressure output. See the Internal Workings Schematic. Input current controls the torque motor stage, a bridge network consisting of an armature mounted on a torsion pivot and suspended in the air gap of a magnetic field. Two permanent magnets polarized in parallel and a connecting plate form a frame for the magnetic bridge. At null the armature is centered in the air gap between the magnets' opposing poles by the equivalence of their magnetic forces and the null-adjust centering springs. As input current rises, the end of the armature becomes biased either north or south, depending on the direction of the current. The resulting armature movement is determined by the amperage of control current, the spring constant and the differential pressure feedback forces (which seek a torque balance, as explained below). Linearity of the input/output relationship is less than 10% through 80% of rated current.

The magnetic bridge output, the flapper torque, in turn controls the hydraulic bridge ratio. At null, the flapper is centered between two nozzles. Upstream from each nozzle is an orifice which provides a nominal pressure drop when the system is at null. Between the nozzle and the orifice on each side is a control port. As the torque shifts the flapper away from one nozzle towards the other, a differential control pressure results, the high side being the one nearer the flapper.

The PCP is a closed-loop pressure control valve using internal hydraulic pressure reactions to effect an intrinsic feedback. With a step input from the current source, the flapper initially moves towards full stroke to close the (commanded) high-side nozzle. Fluid pressure rises on this side and moves the flapper back towards null. When the torque output from the motor equals the torque output from the pressure feedback, the system is in equilibrium. Differential pressure is then proportional to command current.

INTERNAL WORKINGS SCHEMATIC

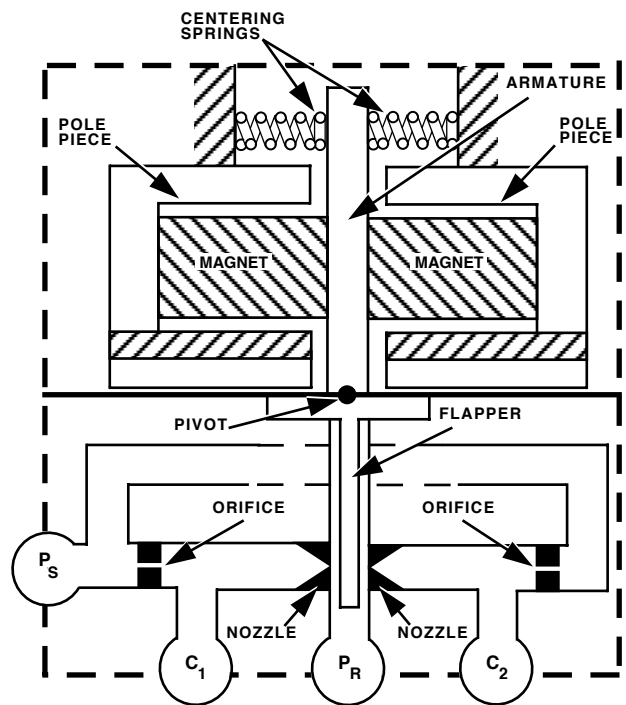

1025

Pressure Control Pilot (at null).

FEATURES

- Standard manual override
- Withstands mobile equipment vibration and shock conditions
- Controls both pilot-operated pumps/motors and main spool valves
- Optional environmental electrical connector (see PCP Mating Connectors, page 10)
- Self-contained pressure feedback
- Constant scale factor with varying pilot pressure
- Can be used in either closed loop or open loop systems

MCV116 DIMENSIONS

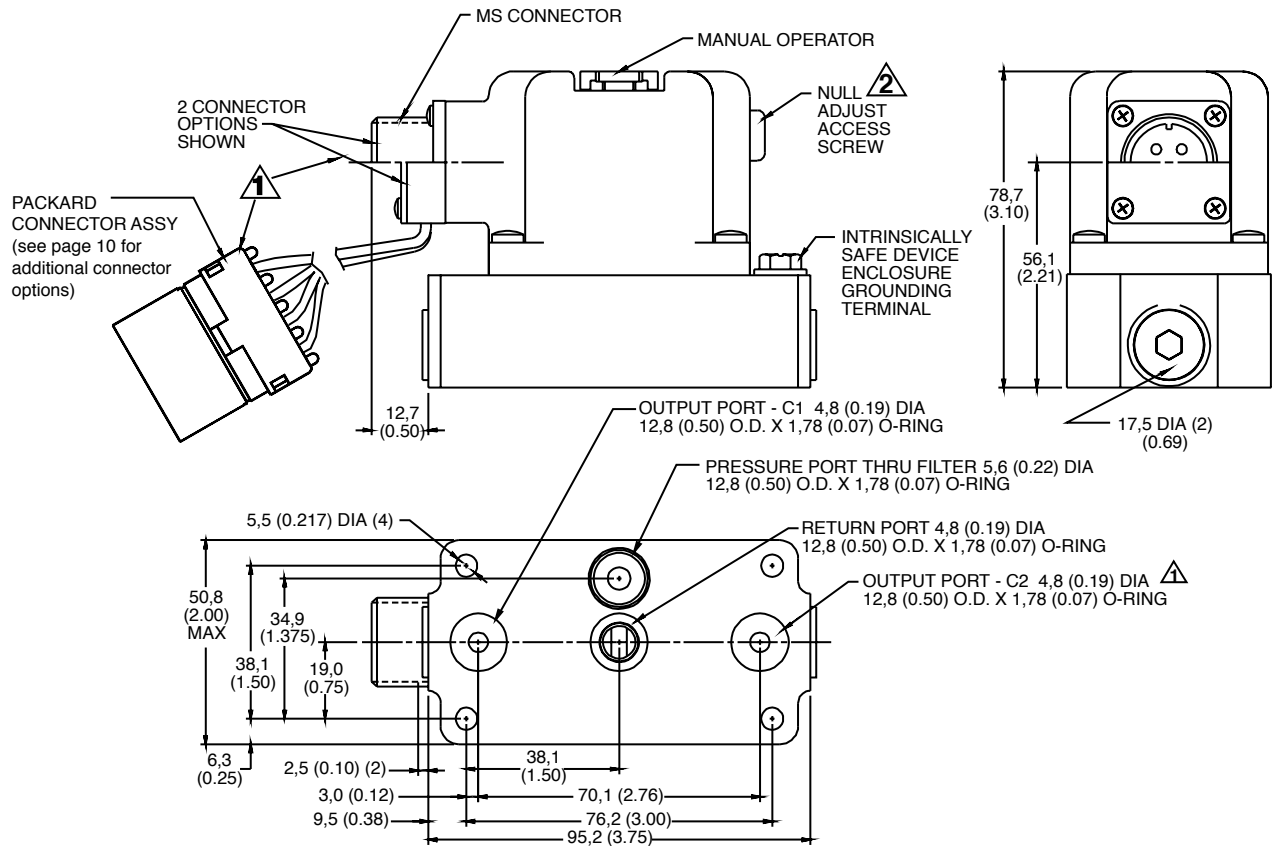

Phasing-

Positive voltage to either red lead (Pins B or D on either the Packard or MS Connector; or pins 2 or 4 of the Duetsch Connector) produces a pressure rise at Output Port-C2.



Null Adjust-

Remove screw, make null adjustment with 3/32 inch hex key, replace screw. Adjust only for special offset considerations, or when adjusting neutral for the Flow Control Servo Valve (KVF).

1640C

CAUTION

If the pilot is used as the first stage of electrical displacement control (EDC), pump or motor, do not adjust the pilot null. Adjust the second stage valve null.

Dimensions of the MCV116 Pressure Control Pilot (PCP) Valve in Millimeters (Inches).

PERFORMANCE

FREQUENCY RESPONSE

Defined at -90° phase lag using a sine wave equal to $\pm 30\%$ input amplitude of the test current loaded into a 34.5 bar differential pressure transducer (load capacitance 0.000143 cubic centimeters/bar) and 8 cubic centimeters of oil on each side between the valve and the transducer. Response bandwidth will decrease with increasing flow demanded by the driven load. See Frequency Response.

OUTPUT SYMMETRY

Defined as the difference of the differential output pressure obtained over the test current high and low end divided by the larger number, expressed as a percentage.

MINIMUM OUTPUT RANGE

Rated at saturation current.

LINEARITY

Defined by measuring the deviation of the center of a test hysteresis loop from the best straight line between the positive and negative extremes of the test current range, expressed as a percentage of the range.

THRESHOLD

Defined as the input signal to produce a detectable pressure change.

HYSTERESIS

Defined at 0.01 Hz cycled through the test current range.

TYPICAL NULL AS SHIPPED

Defined as the output offset at the center of the hysteresis loop at zero input current.

LOAD FLOW

Defined across a 6.9 bar (100 psi) load pressure drop at saturation current. See Load Pressure Droop Slope, page 4.

LOAD PRESSURE DROOP SLOPE

Defined at 17.23 bar (250 psi) supply and 50 mA input. See Load Pressure Droop Slope, page 4.

PRESSURE NULL SHIFT

Defined as a percentage of supply pressure change when supply pressure is varied from 10.3 bar to 34.5 bar.

TEMPERATURE NULL SHIFT

Defined as the maximum temperature null shift per 55.6°C (100°F) from -29° to 121°C (-20° to 250°F).

SATURATION CURRENT

Defined as the magnetic saturation of the torque motor.

SCALE FACTOR

See Scale Factor in the table MCV116 Specifications, page 5.

FREQUENCY RESPONSE

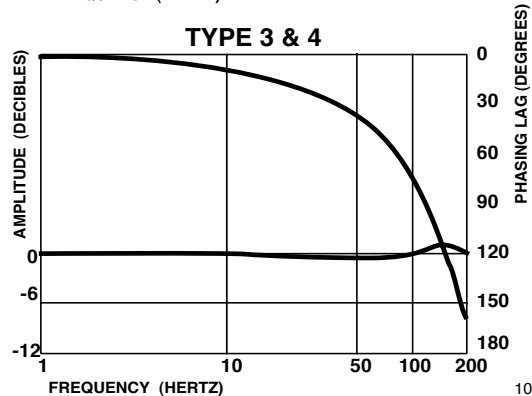
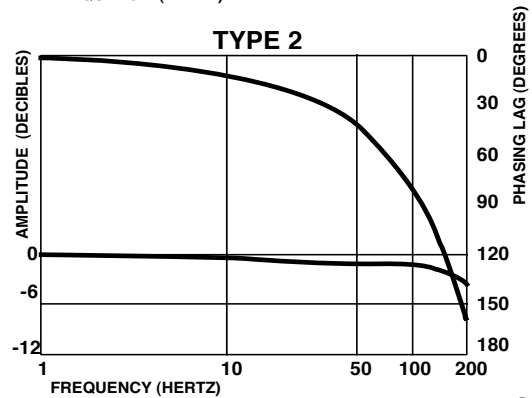
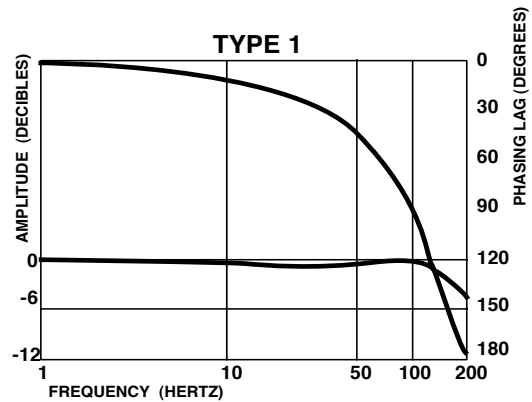

1076A

These curves demonstrate the amplitude and phase response of the valve tested over a given frequency range with a supply pressure of 17.23 bar. Frequency response curves are on the bottom of the graph, phase lag on top. The amplitude at low frequency was ± 30 mA and the load was a 34.47 bar transducer. Frequency response varies with the applied load. Curves are shown with a current driver.

LOAD PRESSURE DROOP SLOPE

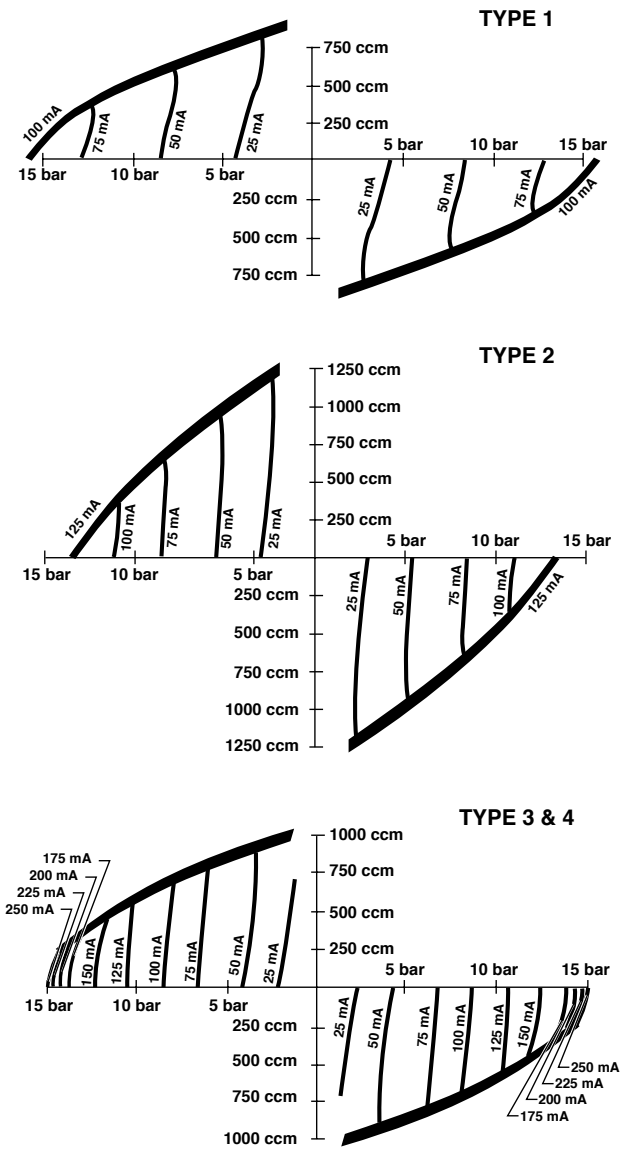

1075A

These curves demonstrate the output impedance characteristics of the valve. Output flow versus output differential pressure are shown at various positive and negative constant input currents. The slopes of these curves indicate the output conductance (load pressure droop slope) or impedance of the valve. Supply pressure is 17.23 bar. Dual coil and low current coil devices have similar load pressure droop slope curves at proportionally different steady current levels.

SCALE FACTOR

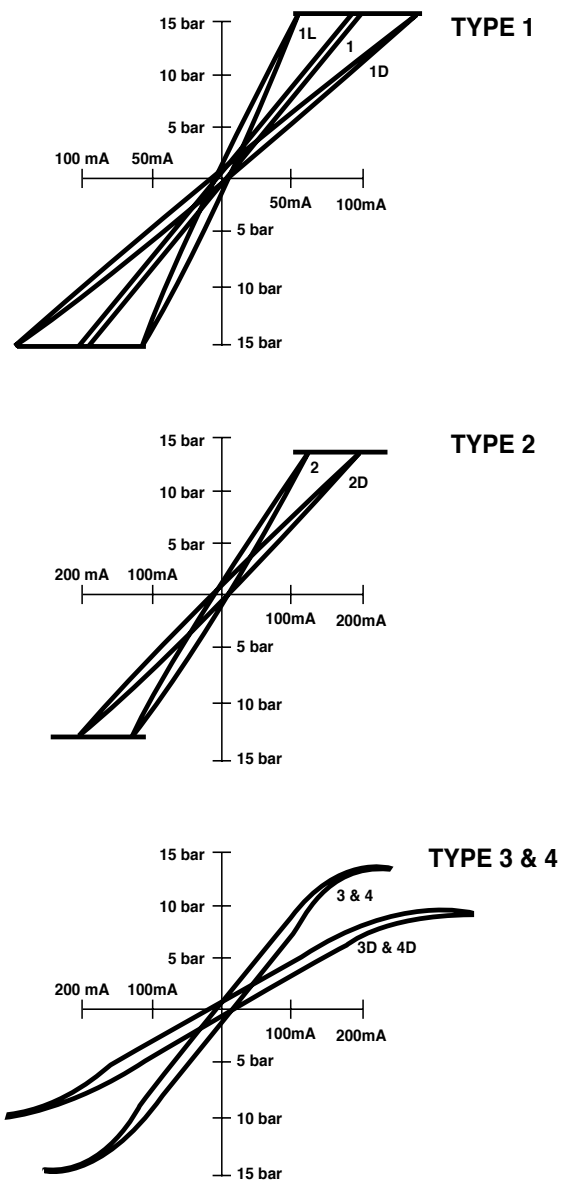

1074C

These curves demonstrate the typical relationship between input current and output differential pressure. Curve slopes are insensitive to input pressure, temperature and load. Supply pressure is 17.23 bar.

ENVIRONMENTAL DATA

SHOCK

50 G for 11 ms. Three shocks in both directions of the three mutually perpendicular axes for a total of 18 shocks.

VIBRATION

Withstands a vibration test designed for mobile equipment controls consisting of two parts:

1. Cycling from 5 to 2000 Hz in each of the three axes.

2. Resonance dwell for one million cycles for each resonance point in each of the three axes. Run from 1 to 46 G. Acceleration level varies with frequency.

HUMIDITY

After being placed in a controlled atmosphere of 95% humidity at 49°C (120°F) for 10 days, the pilot will perform within specification limits.

MCV116 SPECIFICATIONS

	Type 1						Type 2	
	U/M	A11XX	A12XX	A13XX	A14XX	A15XX	A21XX	A22XX
Scale Factor	Delta bar/mA	.165 ± .014	.101 ± .010	.282 ± .028	.378 ± .034	.866 ± .082	.107 ± .010	.069 ± .007
	Delta psi/mA	2.4 ± .2	1.47 ± .15	4.1 ± .4	5.5 ± .5	12.6 ± 1.2	1.55 ± .15	1.00 ± .1
Typical Supply Pressure	bar	34.4	34.4	34.4	34.4	34.4	17.2	17.2
	psi	500	500	500	500	500	250	250
Coil Resistance	ohms	23 (32)	19/15.5 (25/22)	69 (92)	106 (145)	643 (900)	23 (32)	19/15.5 (25/22)
Coil Inductance	henries	0.078	0.062/0.047	0.25	0.399	2.25	0.078	0.062/0.047
Test Current	mA	± 85	± 125	± 42	± 40	± 13	± 85	± 125
Saturation Current	mA	250	350*/175**	150	110	50	250	350*/175**
Minimum Pressure Output Range	Delta bar	± 20.7	± 20.7	± 20.7	± 20.7	± 20.7	± 11.0	± 11.0
	Delta psi	± 300	± 300	± 300	± 300	± 300	± 160	± 160
Typical Null as Shipped	Delta bar	0 ± 0.35	0 ± 0.35	0 ± 0.35	0 ± 0.35	0 ± 0.35	0 ± 0.35	0 ± 0.35
	Delta psi	0 ± 5	0 ± 5	0 ± 5	0 ± 5	0 ± 5	0 ± 5	0 ± 5
Pressure Null Shift	%	± 2	± 2	± 2	± 2	± 2	± 1.5	± 1.5
Temperature Null Shift	Delta bar	± 0.28	± 0.28	± 0.28	± 0.28	± 0.28	± 0.21	± 0.21
	Delta psi	± 4	± 4	± 4	± 4	± 4	± 3	± 3
C1/C2 Null Pressure at Typical Supply Pressure	bar	11.0 ± .68	11.0 ± .68	11.0 ± .68	11.0 ± .68	11.0 ± .68	7.9 ± .34	7.9 ± .34
	psi	160 ± 10	160 ± 10	160 ± 10	160 ± 10	160 ± 10	115 ± 5	115 ± 5
Internal Leakage	LPM	< 3.44	< 3.44	< 3.44	< 3.44	< 3.44	< 3.44	< 3.44
	cis	< 3.5	< 3.5	< 3.5	< 3.5	< 3.5	< 3.5	< 3.5
Load Flow	LPM	> 0.73	> 0.73	> 0.73	> 0.73	> 0.73	> 0.73	> 0.73
	cis	> 0.75	> 0.75	> 0.75	> 0.75	> 0.75	> 0.75	> 0.75
Load Pressure Droop Slope	LPM/bar	> 0.285	> 0.285	> 0.285	> 0.285	> 0.285	> 0.428	> 0.428
	cis/psi	> 0.02	> 0.02	> 0.02	> 0.02	> 0.02	> 0.03	> 0.03
Hysteresis	%	< 9	< 9	< 9	< 9	< 9	< 7	< 7
Symmetry	%	< 10	< 10	< 10	< 10	< 10	< 10	< 10
Linearity	%	< 5	< 5	< 5	< 5	< 5	< 5	< 5
Threshold	mA	< 1	< 1	< 5	< 0.2	< 0.05	< 1	< 1
Resonant Frequency	Hz	> 300	> 300	> 300	> 300	> 300	> 350	> 350
Frequency Response with Current Driver	Hz (min.)	150	150	150	150	150	150	150
Maximum Voltage	Volts	7.5	6	12	12	30	7.5	6
Maximum Current	mA	375	375	175	115	46	375	375

	Type 3				Type 4		
	A31XX	A32XX	A35XX	F31XX	A42XX	F42XX	G42XX
Scale Factor	.079 ± .007	.054 ± .005	.428 ± .043	.079 +/- .007	.079 +/- .007	.079 +/- .007	.079 +/- .007
	1.15 ± .1	.78 ± .08	6.2 ± .6	1.15 +/- .1	1.15 +/- .1	1.15 +/- .1	1.15 +/- .1
Typical Supply Pressure	17.2	17.2	17.2	24	24	24	24
	250	250	250	350	350	350	350
Coil Resistance	23 (32)	19/15.5 (25/22)	643 (900)	23 (32)	19/15.5 (25/22)	19/15.5 (25/22)	19/15.5 (25/22)
Coil Inductance	0.078	0.062/0.047	2.25	0.078	0.062/0.047	0.062/0.047	0.062/0.047
Test Current	± 85	± 125	16	85	85	85	85
Saturation Current	250	350*/175**	50	250	250/125	250/125	250/125
Minimum Pressure Output Range	± 12.4	± 12.4	± 12.4	± 180	± 180	± 160	± 160
	± 180	± 160	± 180	± 180	± 180	± 160	± 160
Typical Null as Shipped	0 ± 0.138	0 ± 0.138	0 ± 0.138	0.1 ± 0.138	0.1 ± 0.138	0.1 ± 0.138	0.1 ± 0.138
	0 ± 2	0 ± 2	0 ± 2	1.5 ± 2	4.5 ± 2	1.5 ± 2	1.5 ± 2
Pressure Null Shift	± 1	± 1	± 1	< 1	< 1.5	< 1.5	< 1.5
Temperature Null Shift	± 0.14	± 0.14	± 0.14	0.14	0.21	0.21	0.21
	± 2	± 2	± 2	2	3	3	3
C1/C2 Null Pressure at Typical Supply Pressure	3.8 ± .34	3.8 ± .34	3.8 ± .34	3.5-4.1	10.3-11.7	10.3-11.7	3.5-4.1
	55 ± 5	55 ± 5	55 ± 5	50-60	120-160	120-160	60-80
Internal Leakage	< 2.46	< 2.46	< 2.46	< 2.46	< 3.44	< 3.44	< 3.44
	< 2.5	< 2.5	< 2.5	< 2.5	< 3.5	< 3.5	< 3.5
Load Flow	> 0.49	> 0.49	> 0.49	> 0.49	> 0.49	> 0.49	> 0.49
	> 0.5	> 0.5	> 0.5	> 0.5	> 0.5	> 0.5	> 0.5
Load Pressure Droop Slope	> 0.570	> 0.570	> 0.570	> 0.570	> 0.570	> 0.570	> 0.570
	> 0.04	> 0.04	> 0.04	> 0.04	> 0.04	> 0.04	> 0.04
Hysteresis	< 7	< 7	< 7	< 7	< 7	< 7	< 7
Symmetry	< 10	< 10	< 10	< 10	< 10	< 10	< 10
Linearity	< 3	< 3	< 3	< 3	< 3	< 3	< 3
Threshold	< 1	< 1	< 1	< 1	< 1	< 1	< 1
Resonant Frequency	> 400	> 400	> 400	> 400	> 300	> 300	> 300
Frequency Response with Current Driver	150	150	150	150	150	150	150
Maximum Voltage	7.5	6	30	7.5	6	6	6
Maximum Current	375	375	46	375	375	375	375

* Individual coils; **Coils in series; See Pressure Control Pilot Valve (PCP) Part Number Reference Guide, page 6, for difference between F42XX and G42XX.

PRESSURE CONTROL PILOT (PCP) VALVE PART NUMBER REFERENCE GUIDE

Unit	P/N MCV116	Where Used	Electrical Connector	Mating Conn	Coil Ohms	Scale Factor psid/mA	Replaces MCV101	C1 & C2 Pressure at null, typical, psi	Current mA Typical max.
1	A1100	Special	10	None	23	2.4	A1016	150 to 170	0 to 150
2	A1101	Servo V. KVF	1	K08106	23	2.4	A1289	150 to 170	0 to 150
3	A1102	Servo V. KVF	3	K03383	23	2.4	A1065	150 to 170	0 to 150
4	A1201	Servo V. KVF	1	K08106	15.5 & 19	1.47	A1388	150 to 170	0 to 220
5	A1203	Servo V. KVF	3	K08106	15.5 & 19	1.47		150 to 170	0 to 220
6	A1204	Servo V. KVF	2	K03384	15.5 & 19	1.47	A1354	150 to 170	0 to 220
7	A1301	Servo V. KVF	3	K08106	69	4.1	A1396	150 to 170	0 to 42
8	A1302	Servo V. KVF	3	K03383	69	4.1	A1362	150 to 170	0 to 42
9	A1307	Servo V. KVF	2	K08106	69	4.1	A1370	150 to 170	0 to 42
10	A1401	Servo V. KVF	1	K08106	106	5.5	A1402	150 to 170	0 to 42
11	A1402	Servo V. KVF	3	K03383	106	5.5	A1404	150 to 170	0 to 42
12	A1407	KVF Special	1	K08106	106	5.5	A1412	150 to 170	0 to 42
13	A1501	Servo V. KVF	1	K08106	643	12.6	A1420	150 to 170	0 to 13
14	A2100	Special	10	None	23	1.55	A1024, A1032, A1107	110 to 120	< 150
15	A2101	Servo V. MCV102	1	K08106	23	1.55	A1297	110 to 120	0 to 150
16	A2102	Servo V. MCV102	3	K03383	23	1.55	A1040	110 to 120	0 to 150
17	A3101	EDC S-20,M-46	1	K08106	23	1.15	A1313, A1347	50 to 60	0 to 90
18	A3102	EDC S-20,M-46	3	K03383	23	1.15	A1214, A1255	50 to 60	0 to 90
19	A3105	EDC Special	5	K10552	23	1.15		50 to 60	0 to 90
20	A3201	EDC S-20,M-46	1	K08106	15.5 & 19	0.78	A1339	50 to 60	0 to 130
21	A3203	Servo V. KVF	3	K03383	15.5 & 19	0.78	A1456	50 to 60	0 to 220
22	A3204	EDC S-20,M-46	2	K03384	15.5 & 19	0.78	A1248	50 to 60	0 to 130
23	A3206	Special	4	K12812	15.5 & 19	0.78		50 to 60	0 to 150
24	A3501	EDC all 4-20 mA	1	K08106	643	6.2		50 to 60	4 to 20
25	A3502	Special	3	K03383	643	6.2		50 to 60	4 to 20
26	A3602	Servo V. KVF	3	K03383	34.5	1.56		50 to 60	< 150
27	A4201	EDC S-90 MCV114	1	K08106	15.5 & 19	1.15		120 to 160	0 to 90
28	A4204	EDC S-90 MCV114	2	K03384	15.5 & 19	1.15		120 to 160	0 to 90
29	F3112	EDC S-90 Special	8	K22569	23	1.15		120 to 160	0 to 90
30	F3113	EDC S-90 Special	7	K26500	23	1.15		120 to 160	0 to 90
31	F4201	EDC S-90 KVEA	1	K08106	15.5 & 19	1.15		120 to 160	0 to 90
32	F4204	EDC S-90 KVEA	2	K03384	15.5 & 19	1.15		120 to 160	0 to 90
33	F4211	EDC S-90 Special	6	K22254	15.5 & 19	1.15		120 to 160	0 to 90
34	G4201	EDC S-90 KVEB	1	K08106	15.5 & 19	1.15		60 to 80	0 to 90
35	G4204	EDC S-90 KVEB	2	K03384	15.5 & 19	1.15		60 to 80	0 to 90
36	G4211	EDC S-90 Special	6	K22254	15.5 & 19	1.15		60 to 80	0 to 90
37	G4213	EDC S-90 Special	7	K26500	15.5 & 19	1.15		60 to 80	0 to 90
38	G4214	EDC S-90 Special	9	K23511	15.5 & 19	1.15		60 to 80	0 to 90
39	C1101	Intrinsically Safe	1	K08106	23	2.4	C1014	150 to 160	< 100
40	C1201	Intrinsically Safe	1	K08106	15.5 & 19	1.47	C1030	150 to 160	< 100
41	C3101	Intrinsically Safe	1	K08106	23	1.15	C1006, C1063	150 to 160	0 to 100
42	C3201	Intrinsically Safe	1	K08106	15.5 & 19	0.78	C1055	150 to 160	0 to 130
43	C1401	Intrinsically Safe	1	K08106	106	5.5		150 to 170	0 to 20

Units 5 & 21 are configured with two 2-pin connectors, one for the A/B coil and one for the C/D coil.

Unit 24 is used on all EDCs with a current range of 4-20 mA, with the exception of the Series 42, which has no removable PCP.

Unit 30 has only 2 lead wires terminating into the 4-pin connector

Units 33, 36 & 37 do not have a manual override.

Units 34 - 37 are the result of a product improvement (see PIB 9810 & SB 99001) and should be used with the KVEB style of EDC.

Unit 43 is used on Series 90 EDCs that are Intrinsically Safe with a current range of 4-20 mA.

ELECTRICAL CONNECTOR	1 MS	2 Packard Weather-pack 4-pin shroud	3 Packard Weather-pack 2-pin shroud
4 Packard Metri-pack 4-pin (5 cavity) 280 series male	5 Packard Metri-pack 2-pin 280 series male		
6 Packard Metri-pack 4-pin 150 series female	7 Packard Metri-pack 4-pin 150 series male	8 Packard Metri-pack 2-pin 150 series male	
9 Deutsch 4-pin plug DT series	10 Lead wires only, 4 inch	NOTE: See PCP Mating Connectors, page 10 for mating connector information.	

SPECIFICATIONS *(continued)*

AMBIENT OPERATING TEMPERATURE

-40°—93°C (-40°—200°F)

OIL TEMPERATURE

-29°—107°C (-20°—225°F)

OIL VISCOSITY

40 SSU—1400 SSU

LIFE

10,000 hours or 10,000,000 cycles minimum

WEIGHT

0.73 kg (1.6 lb)

HYDRAULIC

OPERATING SUPPLY PRESSURE

10.3—68.9 bar (150—1000 psi)

OPERATING RETURN PRESSURE

Less than 13.8 bar (200 psi)

FLUID

The valve is designed for use with petroleum based hydraulic fluids. Other fluids may be used provided that compatibility with viton and fluorosilicone seals is maintained.

SYSTEM FILTRATION

The system hydraulics will have a filtration rating of B₁₀ or better.

ELECTRICAL

PULSE WIDTH MODULATION

When using a pulse width modulated current input, do not exceed rated currents for single coil devices or the algebraic sum of the rated currents in coils A and B for dual coil devices. Pulse width modulated frequencies of greater than 200 Hz are recommended.

WIRING

Optional wiring styles are available: pigtail, MS, Packard Weather Pack, Packard Metri-Pack, and Deutsch DT Series. The pigtail connector is 89 mm (3.5039 in) long and is either two or four wire.

As with all PCP connectors, phasing is such that a positive voltage to either red wires causes a pressure rise at the C2 port.

The MS connector, MS3102C14S-2P (Sauer-Danfoss part number K01314), has four pins, two of which (A and B) are used on single coil devices. See MS Connector Pin Orientation, page 8. For single and dual coil wiring schemes see Connection Diagram, page 8.

The mating connector for MS connectors is part number K08106 (right angle).

The mating connector for Weather Pack PCPs is part number K03384 (four terminal) or K03383 (two terminal). The mating connector for Metri-Pack PCPs is part number K12812 (four terminal) or K10552 (two terminal). For twin two-terminal PCPs, order two K03383 bag assemblies.

Included in the Weather Pack and Metri-Pack bag assembly:

2 (or 4): 14—16 gauge terminals

2 (or 4): 18—20 gauge terminals

1: plastic housing

2 (or 4): green cable seals (for small gauge wires)

2 (or 4): gray cable seals (for medium gauge wires)

2 (or 4): blue cable seals (for large gauge wires)

To assemble the Weather Pack and Metri-Pack mating connector:

1. Isolate the wires that extend from the command source to the PCP.

2. Strip back the insulation 5.5 mm (2.21653 in) on these wires.

3. Push a ribbed cable seal over each of the wires with the smaller diameter shoulder of the seals toward the wire tip. Select the seals that fit tightly over the wires. The distance from the tip of the wires of the first (nearest) rib should be 9.5 mm (.37401 in). Thus, the insulation should just protrude beyond the seal.

4. Select the appropriate set of terminals for the gauge wire used. Place the wire into the socket so that the seal edge is pushed through and extends slightly beyond the circular tabs that hold it in place. Crimp with a Packard 12014254 crimp tool. See Connector Crimp (Metri-Pack 280 Series), page 8. The distance from the back of the tangs to the furthest rib may not exceed 19.5 mm (.7677 in) on the Weather-Pack connector, 18 mm (.7087 in) on the Metri-Pack connector.

5. Insert the assembled wires into the back end (large hole) of the plastic housing. Push until the wires detent with an audible click, then pull back slightly to ensure proper seating. Observe the proper phasing of the wires when installing: black wire to "A", red wire to "B", black to "C" and red to "D" (red to "E" if Metri-Pack).

6. Swing the holder down into the detented position to trap the wires in the housing.

7. Plug the two connector halves together, see Connector Parts (Metri-Pack 280 Series), page 8.

CONNECTION DIAGRAM

Fig. 1: Single Coil



Fig. 2: One of Dual Coils

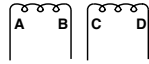

Fig. 3: Dual Coils in Series

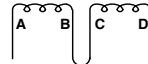

Fig. 4: Dual Coils in Parallel

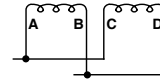

Fig. 1 (common)

For potentiometer type inputs signals where the voltage is divided to achieve a change in direction; it is a common practice to use only one of the coils.

Figure 2 (common)

Both coils are required when the input current is a PWM signal from such devices as either an analog driver board or digital controller. A common wiring practice for controlling in both directions is to connect pins B and C to ground, and connect pin A to the forward command and pin B to the reverse command.

Figure 3 (uncommon)

Wiring coils in series may only be required when multiple MCV116XXXXX devices are being controlled, thus reducing the total current.

Figure 4 (uncommon)

Wiring coils in parallel reduces the electrical load, thus reducing the voltage required.

For a listing of MCV116 valves that are either single or dual coil see MCV116 Specifications, page 5.

DEUTSCH DT SERIES

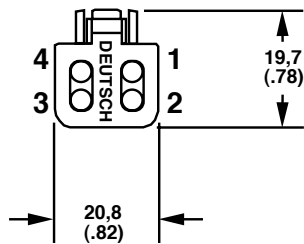

Pin orientation of the Mating 4-pin Deutsch Plug DT Series Connector. (Sauer-Danfoss Part No. K23511).

MS CONNECTOR PIN ORIENTATION

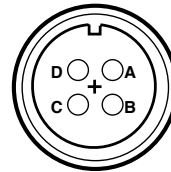

Pin orientation of the optional MS Connector, part number MS3102C14S-2P (K01314). (Not field replaceable).

CONNECTOR CRIMP (WEATHER-PACK)

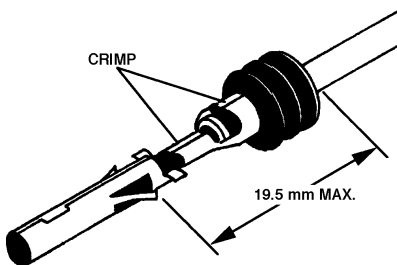

Crimp location and distance from tang to third rib of Packard Weather-Pack Connector.

CONNECTOR PARTS (WEATHER-PACK)

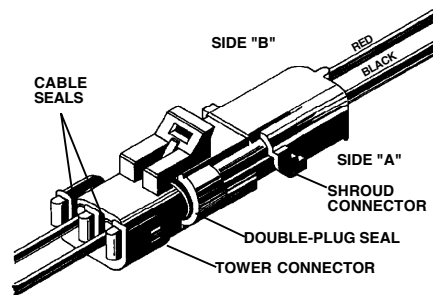

Packard Weather-Pack interlocked connector halves with parts identified.

CONNECTOR CRIMP (METRI-PACK 280 SERIES)

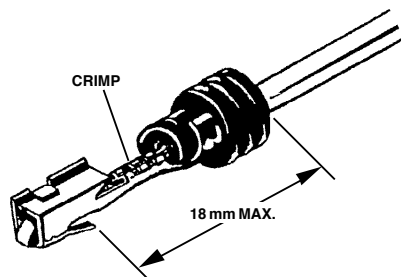

Crimp location and distance from tang to third rib of Packard Metri-Pack Connector.

CONNECTOR PARTS (METRI-PACK 280 SERIES)

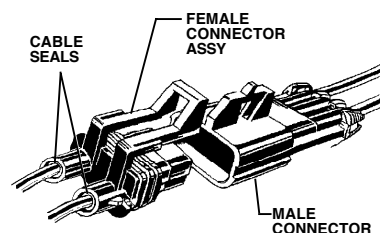

Packard Metri-Pack connector halves with parts identified.

DEUTSCH ASSEMBLY CONTACT INSERTION AND CONTACT REMOVAL

CONTACT INSERTION

1. Grasp crimped contact approximately 25.4 mm (1 in) behind the contact barrel.
2. Hold connector with rear grommet facing you.
3. Push contact straight into connector grommet until a click is felt. A slight tug will confirm that it is properly locked in place.
4. Once all contacts are in place, insert orange wedge with arrow pointing toward exterior locking mechanism. The orange wedge will snap into place. Rectangular wedges are not oriented. They may go in either way.

CONTACT REMOVAL

1. Remove orange wedge using needlenose pliers or a hook shaped wire to pull wedge straight out.
2. To remove the contacts, gently pull wire backwards, while at the same time releasing the locking finger by moving it away from the contact with a screwdriver.
3. Hold the rear seal in place, as removing the contact will displace the seal.

Note: Use the same procedure for the receptacle and plug.

DT SERIES

Contacts Solid - Crimp Type

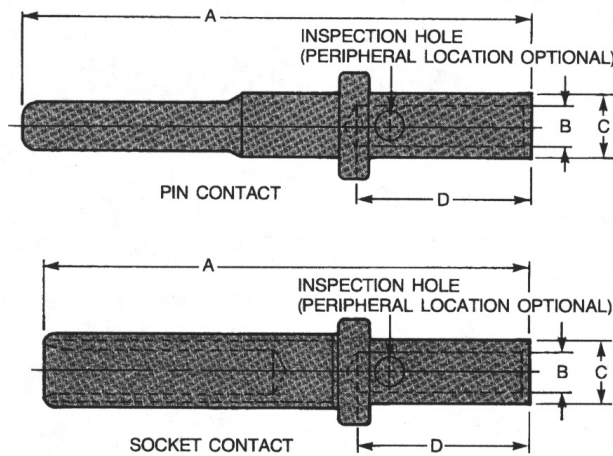

CONTACT PART NUMBER	SIZE & TYPE	A MAX	B MIN	C MAX	D MIN	WIRE GAGE RANGE	RECOMMENDED STRIP LENGTH	HAND CRIMP TOOL
0460-202-16141	16 PIN	.821	.066	.103	.250	16 and 18	.250 to .312	HDT-48-00
0462-201-16141	16 SOC	.759	.066	.103	.250	16 and 18	.250 to .312	HDT-48-00
0460-215-16141	16 PIN	.821	.076	.103	.250	14 and 16	.250 to .312	HDT-48-00
0462-209-16141	16 SOC	.757	.076	.103	.250	14 and 16	.250 to .312	HDT-48-00

PCP MATING CONNECTORS

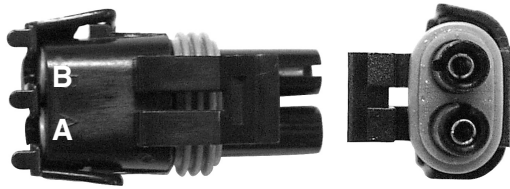

2-pin Packard Weather-Pack Tower Mating Connector Kit: K03383
Packard Crimping and Extracting Tools: 12014254 and 12014012

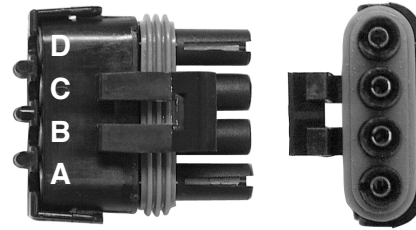

4-pin Packard Weather-pack Tower Mating Connector Kit: K03384
Packard Crimping and Extracting tools: 12014254 and 12014012

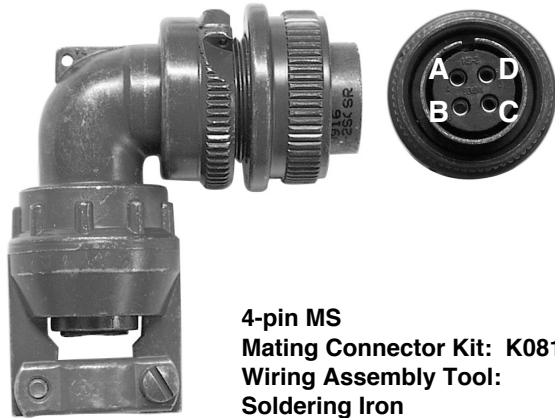

4-pin MS Mating Connector Kit: K08106
Wiring Assembly Tool: Soldering Iron

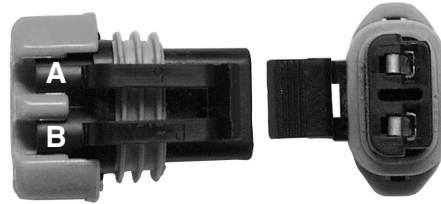

2-pin Packard Metri-Pack Female 280 Series Mating Connector Kit: K10552
Packard Crimping and Extracting tools: (two crimping tools required) 12085271/12085270 and 12094429

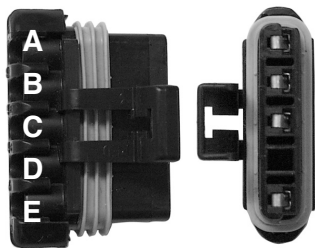

4-pin Packard Metri-Pack Female 280 Series Mating Connector Kit: K12812
Packard Crimping and Extracting tools

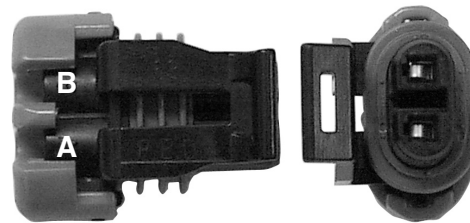

2-pin Packard Metri-Pack Female 150 Series Mating Connector Kit: K22569
Packard Crimping and Extracting Tools

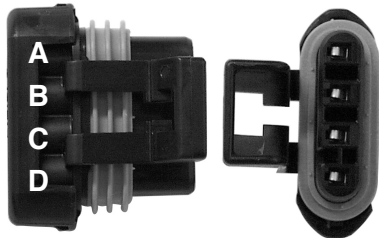

4-pin Packard Metri-Pack Female 150 Series Mating Connector Kit: K26500
Packard Crimping and Extracting Tools

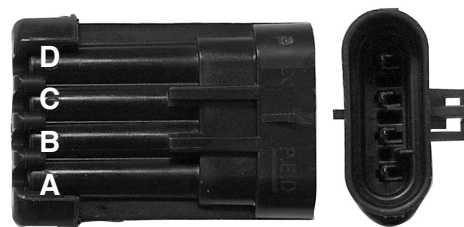

4-pin Packard Metri-Pack Female 150 Series Mating Connector Kit: K22254
Packard Crimping and Extracting Tools



4-pin Deutsch Plug DT Series Mating Connector Kit: K23511
Deutsch Crimping and Extracting Tools: HDT-48-00 and DT/RT1

SPECIAL APPROVAL

In the many industrial processes where flammable materials are handled, any leak or spillage may lead to an explosive atmosphere. To protect both property and personnel, precautions must be taken to ensure that this atmosphere cannot be ignited. The areas at risk are known as hazardous areas and the materials that are commonly involved include crude oil and its derivatives, alcohol, natural and synthetic process starch, grain, fibers, and flyings.

Intrinsic safety is based on the principle of restricting the electrical energy available in hazardous-area circuits such that any sparks or hot surfaces that may occur as a result of electrical faults are too weak to cause ignition. Factory Mutual Research (FM) has approved the following model PCPs for Class I, II, and III Division 1, applicable Group C, D, F, and G hazardous locations in accordance with the appropriate installation drawings: MCV116C1101 Single Coil; MCV116C1401 Single Coil, typically used with Series 90 EDC's with a current range of 4-20 mA; MCV116C2101 Dual Coil; MCV116C3101 Single Coil, typically used with EDC; MCV116C3201 Dual Coil, typically used with EDC.

Example of a typical electrical wiring diagram (unidirectional control).

UNIDIRECTIONAL CONTROL, SELECT ONE OF THE FOLLOWING BARRIERS

- Stahl Barrier 9001/01-158-270-10 (12V)
Groups A, B, C, D, F and G (maximum voltage 15.8V)
- Stahl Barrier 9001/01-280-280-10 (26V)
Groups D, E, F and G (maximum voltage 31.5V)

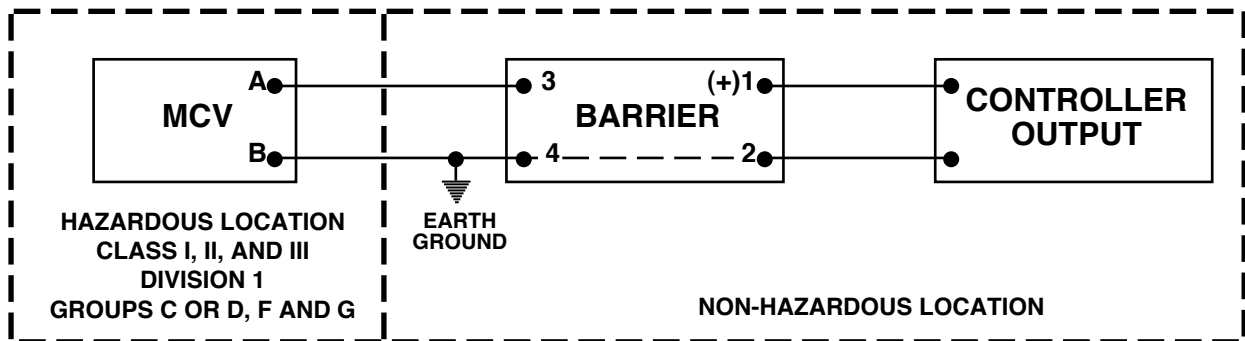

3007

The intrinsically safe PCP valve body is made from steel and has a zinc dichromate finish to prevent corrosion. Suppression circuit is incorporated in the torque motor cover, but by itself does not insure intrinsic safety. An additional suppression circuit (Zener barrier) must be connected in series with the valve coils. The Zener barrier and electrical controller must be isolated from the hazardous area either through use of a purge enclosure or mounted in a safe area.

Example of Zener barrier options (which are manufactured by R. Stahl, Inc., 1-800-782-4357).

UNIT	R. STAHL INC. PART NUMBER	MAX VOLTAGE	INTERNAL RESISTANCE
1	9001/01-158-270-10	15.8	74 ohm
2	9001/02-172-270-10	17.2	80 ohm
3	9001/01-280-280-10	31.51	124 ohm

UNIT	R. STAHL INC. PART NUMBER	MAX VOLTAGE	INTERNAL RESISTANCE
4	9001/01-308-230-10	31.8	158 ohm
5	9001/01-158-150-10	15.8	127 ohm
6	9001/02-175-200-10	17.2	110 ohm

APPLICATION

The MCV coils are arranged on a T-bar-style armature. This allows the coils to be physically separated by a small air gap. MCV116 dual coils are arranged on a stand-up style armature (which is the same used on all other dual coil EDCs and servovalves) and they are stacked one atop the other. In some rare instances, this may induce current changes resulting from the magnetic effects of one coil on another (see the following Precautions When Driving Dual Coil PCPs With A PWM Drive). Contact Sauer-Danfoss with applications concerns.

PRECAUTIONS WHEN DRIVING DUAL COIL PCPS WITH A PWM DRIVER

Sauer-Danfoss dual coil PCPs are constructed in such a

manner that magnetic flux generated in the circuit flows through the windings of both coils, a phenomenon basic to the torque motor technology used. This is different from some magnetic actuators, such as most proportional valves, that have two distinctly separate magnetic circuits.

Since the flux generated in one coil flows through the other coil, the device operates like, and in fact is, a transformer.

This fact is generally insignificant when the coils are driven with dc current, such as when the device is driven from a potentiometric control handle or from dc current drivers such as the valve drivers in Sauer-Danfoss DC2 and SUSMIC microcontrollers.

APPLICATION (continued)

Many controllers are set up to drive proportional solenoids through pulse width modulation (PWM). Sometimes the scheme is used with the field effect transistor (FET) outputs of DC2s or SUSMIC controllers. These controls send an oscillating pulse width modulated dc current to the coil. This scheme has the advantages of providing dither to the actuator and, in some cases, can simplify the electronics since they operate in a digital mode, potentially reducing heat output from the device.

As with most things there are trade offs or unwanted side effects: Items 1 through 3 apply to all electrohydraulic actuators. Items 4 and 5 relate more specifically to PCPs.

1. The pulsing current generates unwanted electromagnetic radiation, which can interfere with related devices.
2. The actuators are generally responsive to current. PWM valve drivers are generally low impedance voltage drives. As the coils heat up, the resistance changes (typically by as much as 50%), thus altering the response of the device. For a given PWM frequency and duty cycle, both peak and average current into the driven coil may strongly affect the coil's L/R (inductance/resistance) time constant, potentially reducing both accuracy and linearity. The effects vary considerably with valve type and with temperature and are quite different between the Sauer-Danfoss MCV116 and MCV110. PWM drivers often require "current feedback" to maintain sufficient accuracy as the temperature varies over the operating range.
3. Some controllers are designed to diagnose shorts or opens in the output circuit. The PWM-induced voltage can affect some common detection schemes.
4. In the case of the PCP, a PWM signal is like an alternating current applied to the primary of a transformer. A voltage is induced in the secondary coil proportional to the turns ratio of the coils less losses in the magnetic circuit. If the secondary coil is open circuited, there is no effect since no current flows, hence no magnetic field is generated. However, if current is allowed to flow in the secondary coil, it flows in a direction which will reduce the output of the actuator.
5. Most electronic drivers will conduct current when back driven with excessive voltages. One example is a drive that contains non-linear devices such as diodes or zener diodes for re-circulatory currents. The induced voltages may be sufficient to cause these devices to conduct, thereby causing current flow in the non-driven coil.

In position control systems where the control drives toward null this generally is not a problem. However, in propel systems, especially dual path propel systems, the change in output velocity could be a severe limitation. In some cases filters can be designed to correct the problem. A limitation of filters is this adds a lag in the circuit which will adversely affect high response systems. Also, it is impossible to design one filter to fit all applications.

In summary, the ability to drive the Sauer-Danfoss PCP depends on many circumstances which must be understood and accounted for by the user.

FREQUENTLY ASKED QUESTIONS

The following questions and answers cover those applications that use the PCP as the pilot stage to a second stage. For example: Electrical Displacement Control (EDC) for Sauer-Danfoss Variable Pumps and Sauer-Danfoss Flow and Pressure Control Servovalves.

1. **Question:** Is the PCP a 12 or 24 volt dc device (i.e., direct battery voltage)?
Answer: Do not apply 12 or 24 volts dc directly to the PCP for several reasons, the most important being the coil will be permanently damaged. And voltage levels beyond 3 volts dc are out of the control range. The exceptions are: (1) the low current (4-20 mA) models, which have a maximum voltage rating of 36 V DC, and (2) when applying a PWM signal from an amplifier.
2. **Question:** Why are some PCP configurations single coil and some dual coil?
Answer: The original design was a single coil, and the dual coil design followed as the standard configuration.
3. **Question:** When should either a dual coil or single coil be specified?
Answer: When uncertain, specify a dual coil. The second coil does not have to be used to be bi-directional when using a potentiometer type inputs. The dual coil configuration can simplify the switching logic when required. The one exception in which a dual coil is not offered are EDCs and Servovalves that have a current range of 4-20 mA.
4. **Question:** When is it a must to use a dual coil?
Answer: When using a Control Handle (MCH) that has a circuit board built into the housing (e.g., MCHxxxLxxx), because the output is switched forward and reverse between two output terminals. This switched output current is approximately 0—3 volts. With this type of output scheme, use one coil for reverse and the other coil for forward. However, most MCH models have a voltage/current output based on a bridge circuit, which uses approximately a 6 volt reference on each of the two outputs terminals. As the MCH is moved between forward and reverse, the voltage swings up and down from 6 volts. Also, when using either an analog amplifier or a microcontroller both coils would be used to achieve bi-directional control.
5. **Question:** Can the PCP alone be changed on an EDC to achieve 4-20 mA control?
Answer: Simply changing the PCP is not a solution, because the second stage (i.e., EDC) is calibrated using different internal spring forces to match a specific high gain (psid/mA) PCP (MCV116A3501).
6. **Question:** What is the purpose of having silicone oil inside the cover?
Answer: The original PCP Valves design did not have silicone oil, but shortly thereafter it was added to all PCP models to reduce the effects of the environment. The loss of silicone oil to those PCP's that are used on the Servovalve (KVF models) may cause a loss in valve performance, and therefore it is recommended to replace the silicone oil in the event it is removed or lost. See item 6 on page 13 for replacement kit.

SERVICE PARTS

WARNING

**Regarding Service Parts List, Item 3:
DO NOT Remove Cover Screws unless replacing cover.**

Service Parts List.

ITEM	P/N	QTY	DESCRIPTION
1	K01291	2	SAE-6 Plugs
2	K07067	4	PCP Mounting Screws
3	K02264	4	PCP Cover Screws
4	K26275	1	3/8-24 PCP Null Access Screw
	K00920	1	1/4-28 PCP Null Access Screw
5	K28475	1	PCP Cover Kit
6	K21436	1	Silicone Oil Kit 4000 cs
7	K04790	1	Connector O-ring
8	K08687	4	Connector Screw for MS
9	K01314	1	Connector MS
10	K08688	4	Connector Screw for Packard
11	K08106	1	Mating Electrical Connector MS
12	K08014	1	Feed Through Assy Cover Plate
13	K07533	1	Feed Through Assy 4-pin Packard W-P
	K24223	1	Feed Through Assy 4-pin Deutsch
14	K03384	1	Mating Electrical Packard W-P 4-pin
	K23511	1	Mating Electrical Deutsch 4-pin
15	K00829	2	O-ring Control Port
16	K00830	1	O-ring Return Port
17	K08573	1	Filter Assy with O-rings
18	K08493	1	O-ring Pressure Port

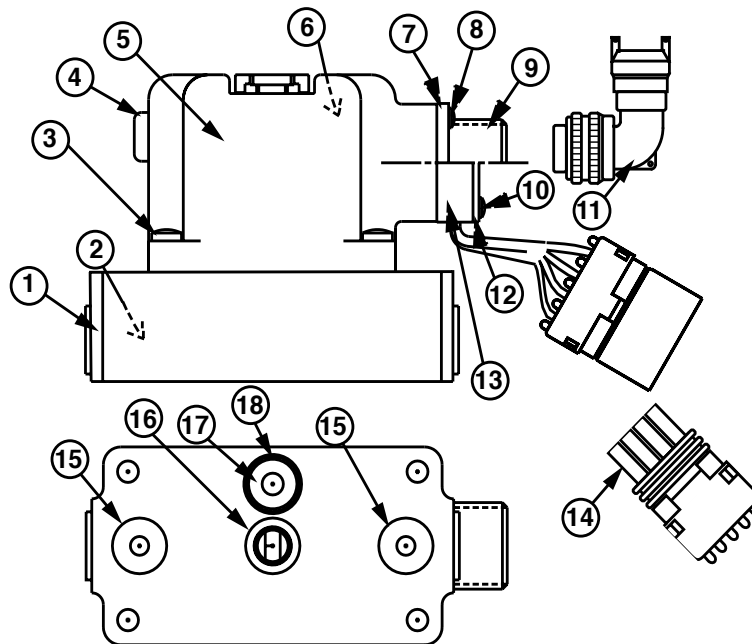

3001B

Note: The Deutsch electrical connectors are not shown. See Item 4, a change was made in January 2000 that increased the null access opening thread size from 1/4-28 to 3/8-24, therefore part number K00920 only fits those covers with a 1/4-28 thread size. See Item 5, the preferred part number K28475 includes the cover, gaskets, null access screw, and all the cover seals.

SERVICE PARTS *(continued)*

The following steps are recommended when servicing those parts listed in the Service Parts List, page 13.

Preferred service tools are:

- Screw driver: TX 15 and TX 10
- Solder: SN62
- Needle nose pliers, small tip
- Solder iron: electronic type
- Multimeter
- Cleaning solvent: Chemtronics 2000 ES 1601
- Torque wrench: 0—25 in·lb (0—33 N·m)

REPLACING COVER AND/OR ELECTRICAL CONNECTOR

1. Wipe down external surface to ensure that loose contaminants will not fall inside the housing.
2. Place the valve in a firm position at 45° with the electrical connector tilted upwards. Pressure control pilot valves (PCP) built after 1988 are filled with a silicone oil. Locate and remove the four connector screws (see page 13, Item 8 if MS connector, or Item 10 if Packard connector).
3. Hold the electrical connector and untwist wires by rotating the connector counterclockwise two turns while gently pulling away from the housing.
4. Clean the solder connections inside connection of the electrical connector with degreaser. Unsolder the wires, noting which pin goes to which wire color (e.g., Pin A to black, Pin B to red, Pin C to brown, etc.). With the connector held firmly, place the solder iron against the base solder cup if MS, and pin if Packard, until the wires can be gently pulled away.
5. The cover can now be removed and replaced if required. Be sure the PCP cover gasket is firmly seated into the cover base and is in good condition before cover is installed. Torque cover screws to 12—15 in·lb (16—20 N·m).
6. Verify that wire to pin connections are correct before soldering wires and the connector O-ring (see page 13, Item 7) is in place before soldering.
- 7a. For the MS style connector, ensure that the cups have sufficient solder (approximately level). If additional solder is required, place solder iron against the base of the cup and add solder. While solder is still liquid, place wire in the cup, remove iron and let cool for several seconds while holding wire firmly.
- 7b. For the Packard style connector, the wire should extend around and contact the terminal post for at least 180° (1/2 wrap to a maximum of 270°). When ready to solder, heat the terminal and add solder, remove iron, and let cool for several seconds while holding wire firmly.
8. After soldering, ensure that terminals and wires do not contact one another.
9. If silicone oil is to be added, do so at this step with the connector not yet attached to cover. Tilt cover upward and add 45 cc of oil from container. The container (see page 13, Item 6) holds enough for 3 fills.
10. Before attaching the connector to the cover, rotate connector clockwise two turns. This will bundle the wires together, finishing with the notch up when viewed from the outward side of the MS connector and lead wires down for Packard connector (see MS Connector Pin Orientation, page 8). Insert connector screws and torque to 8—10 in·lb (11—13 N·m).
11. With a multimeter, check for proper coil resistance between terminals A and B, and between C and D if PCP is a dual coil.

MANIFOLDING

Applications in which manufacturers have not provided for direct sub-plate mounting will require a manifold mount. See the Manifold dimension drawing below. To mount the manifold, drill two holes in the machine's panel (or other suitable location) as determined by the dimensions drawing (see MCV116 Dimensions, page 2) and attach with two M8X1.25 screws.

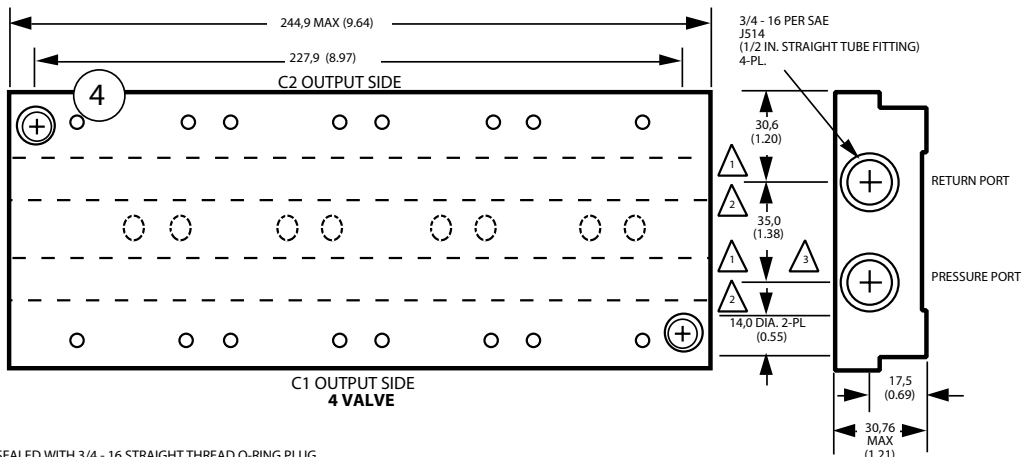
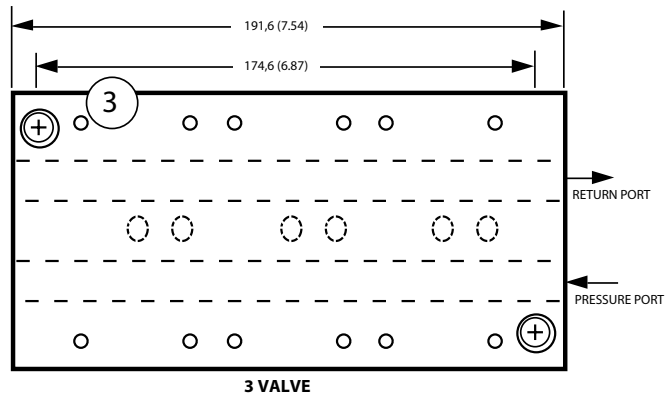
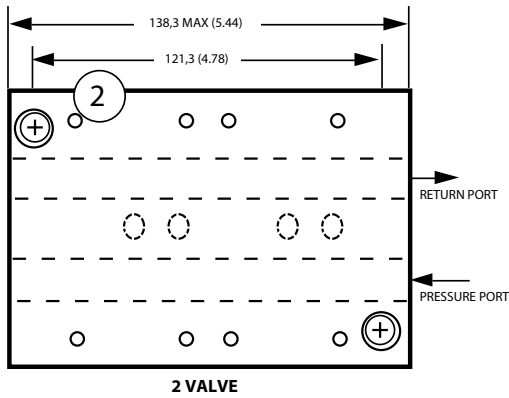
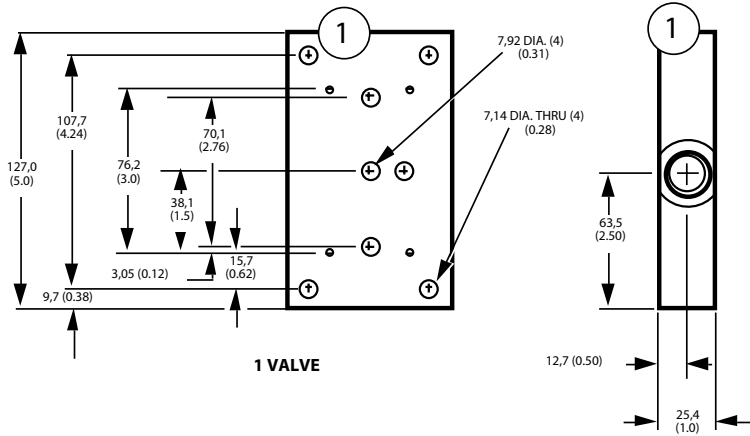

- ▲ SEALED WITH 3/4 - 16 STRAIGHT THREAD O-RING PLUG (SAE 090109 REF.), UNFURNISHED
- ▲ CHOICE OF PLUGGED END OPTIONAL PER USER REQUIREMENTS
- ▲ C1 AND C2 OUTPUTS ARE ACCESSED BY REMOVING THE PILOT VALVE SAE PLUGS, REFER TO THE SPARE PARTS SECTION (ITEM 9)
- ▲ C1 AND C2 PORTS ALLOW DIRECT ACCESS WITHOUT REMOVING PILOT VALVE SAE PLUGS.
- ▲ All manifolds include PCP MOUNTING SCREWS m5 x o.8 x 16 long (K07067)

- ① SINGLE-VALVE MANIFOLD PART NUMBER KK02501
- ② 2-VALVE MANIFOLD PART NUMBER KK01502
- ③ 3-VALVE MANIFOLD PART NUMBER KK01503
- ④ 4-VALVE MANIFOLD PART NUMBER KK01504

Optional MCV116 1, 2, 3, and 4 Stack Manifold Dimensions in Millimeters (Inches).

1027E

TROUBLESHOOTING

1. If the pressure control pilot valve (PCP) does not reach its expected output flow or pressure when applying an electrical signal, actuate the manual operator several times from side to side, but first take the necessary safety precautions in the event full output pressure is reached. If output pressure is reached with the manual operator the problem may be electrical, in which case, skip to step 5.
2. If the manual operator fails to achieve full output in both directions, ensure that a minimum supply pressure is getting to the PCP (e.g., pump charge pressure, servovalve supply). If supply pressure is sufficient, there may be a problem within the PCP such as a lodged particle. Move to step 3 and check for the proper internal pressure reactions.
3. Checking the PCP internal pressures at neutral (null) and with a full rated electrical command can help isolate a problem. First shut off the hydraulic system then locate the two #6 SAE plugs in the sides of the PCP and place a 0—500 psi gage into each of these control ports. If the PCP is attached to the Series 90 EDC, then check pressure at the EDC second stage housing, which has the same size ports as the PCP. The ports are identified as X1 and X2. Once the gages are in place start the system. The gage reading will rise to approximately the specification for a given model (see C1/C2 Null Pressure at Typical Supply Pressure in the table MCV116 Specifications, page 5). Readings should be within 10 psi or less of each other with no command signal (e.g., 65 and 75 psi). If they are greater than 15 psi apart, replace the PCP. If the problem is a creep in one direction from either the pump or servovalve and the gage readings are relatively close to within 10 psi of each other, restoring the valve null is an option. Proceed to step 4. Observe the gage readings while stroking the valve manually, then stroke it electrically. If either case fails to reach the proper minimum differential pressure (psid) level, replace the valve (see Typical Supply Pressure in the table MCV116 Specifications, page 5). The minimum psid can be calculated by multiplying the rated current by the scale factor (see Scale Factor in the table MCV116 Specifications, page 5).
4. To restore the PCP null requires the hydraulic system to be running and a gage in each control port. Locate and remove the null access screw. A small amount of silicone oil likely will escape from this opening, which is acceptable. Then insert a 3/32" Allen wrench just beyond this opening into the adjustment set screw and very slowly adjust clockwise and/or counterclockwise until gages are reading the same. Replace the access screw when finished.
5. Checking for the proper electrical voltage or current requires a Volt Ohm Meter (VOM). To check voltage set meter to the Volt dc scale and place meter leads across the two wires going to the PCP coil. Voltage requirements may vary from one PCP model to another (see Test Current, Table A - MCV116 Specifications, page 5). When checking current, place the VOM in series between the electrical controller and the valve. Set the meter to the dc amp scale and set the range to read milliamperes. The current level should reach the minimum. If the proper internal pressures are reached with the electrical signal, there is likely a problem with the second stage upon which the PCP is mounted, and it should be replaced.

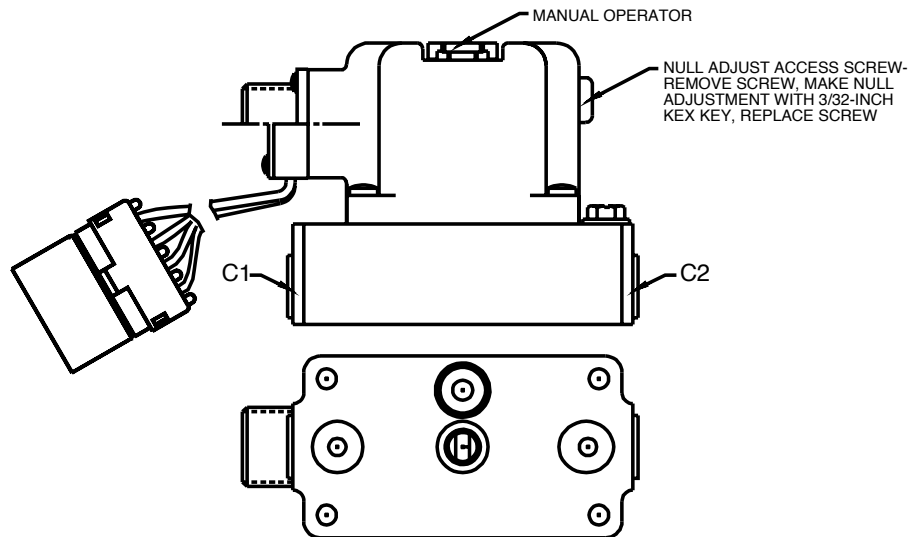

3002A

CAUTION

If the pilot is used as the first stage of an electrical displacement control (EDC), pump or motor, do not adjust the pilot null. Adjust the second stage valve null.

CUSTOMER SERVICE

When ordering a MCV116 Pressure Control Pilot Valve refer to the table MCV116 Pressure Control Pilot (PCP) Valve Part Number Reference Guide, page 6.

NORTH AMERICA

ORDER FROM

Sauer-Danfoss (US) Company
Customer Service Department
3500 Annapolis Lane North
Minneapolis, Minnesota 55447
Phone: (763) 509-2084
Fax: (763) 559-0108

DEVICE REPAIR

For devices in need of repair, include a description of the problem, a copy of the purchase order and your name, address and telephone number.

RETURN TO

Sauer-Danfoss (US) Company
Return Goods Department
3500 Annapolis Lane North
Minneapolis, Minnesota 55447

EUROPE

ORDER FROM

Sauer-Danfoss (Neumünster) GmbH & Co. OHG
Order Entry Department
Postfach 2460, D-24531 Neumünster
Krokamp 35, D24539 Neumünster, Germany
Phone: +49 4321 871-0
Fax: +49 4321 871 122